

380PS

H380

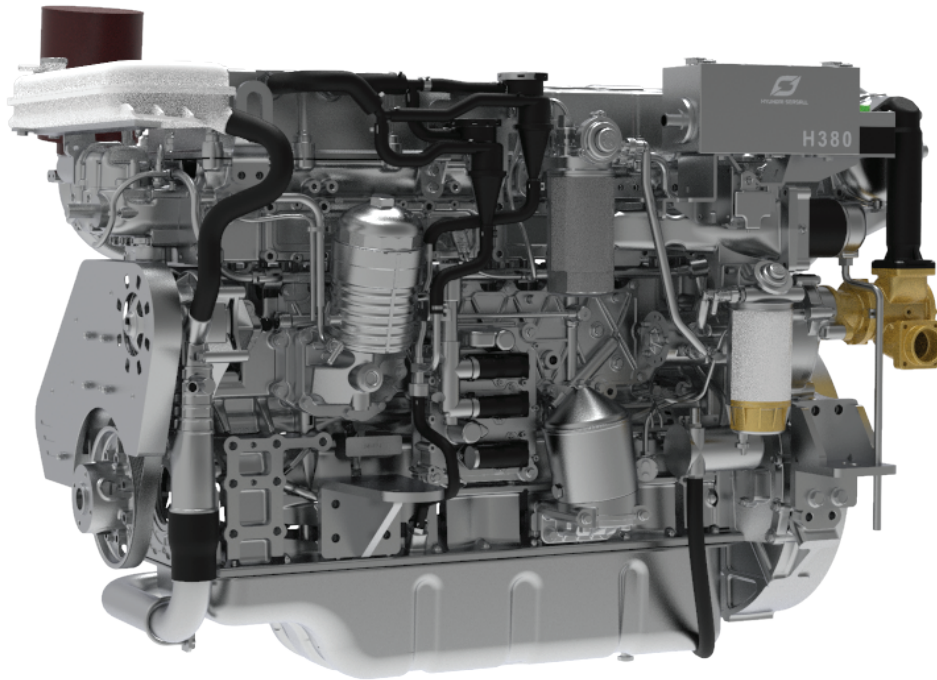

Specifications

Propulsion System	Shaftdrive
Engine Duty Rating	Heavy Duty (S1)
Configuration	4-Stroke, 24-Valve DOHC, E-VGT with Intercooler, Water Cooling
Output [PS (kW)]	380 (280)
Rated RPM	1,800
Cylinders	In-line 6
Displacement [cc]	9,960
Bore X Stroke [mm]	122 X 142
Compression Ratio	16.0 : 1
Max. Torque	170 kg·m @ 1,100 rpm
Injection System	Electronic Unit Injector (EUI)
Alternator	24V-70A
Engine Diagnosis	YES
Max Fuel Consump.[l/h]	70.0
Dry Weight [kg]	1,120
Flywheel	SAE 14
Flywheel Housing	SAE 1

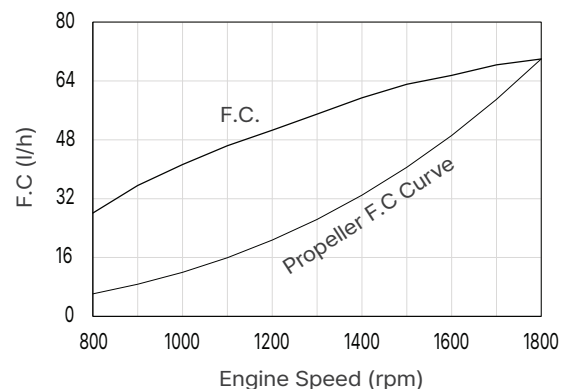
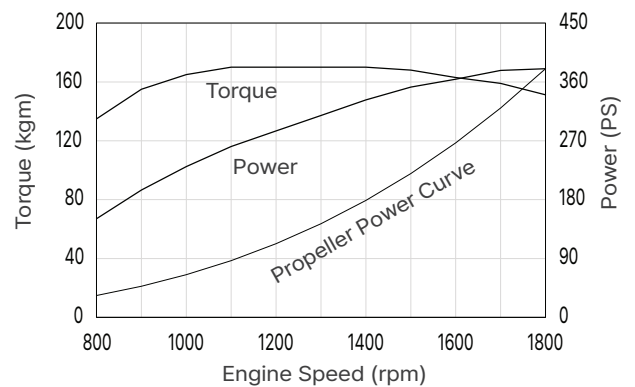

H380

Technical Descriptions

Engine

- 6 cylinder in-line, 24 valve OHC
- Compacted Graphite Iron (CGI) cylinder head
- Cast iron cylinder block
- Gallery cooled long lasting mono steel pistons
- Integrated water jacket
- Single serpentine belt system
- Drive belt auto tensioner

Air Inlet system

- Reusable air filter
- Intake Extension Kit(Optional)

Fuel System

- Electronic Unit Injector (EUI)
- Gear-driven fuel pump
- Electronically controlled injection timing
- Fine fuel filter and water separator
- Adjustable engine mounts (Optional)

Engine Mounting

- Adjustable engine mounts (Optional)

Electrical System

- 24 volt - 70A alternator
- Auxiliary engine stop button
- Air heating system for a trouble-free cold start
- NMEA2000 Converter (Optional)
- 2 Pole system (Optional)

Cooling System

- Gear-driven seawater pump
- Seawater-cooled intercooler, heat exchanger
- Auxiliary connector for cabin heating
- Corrosion resistant material for seawater circuit
- Easily accessible seawater impeller pump

Lubrication System

- Easily exchangeable oil filter cartridge
- Integrated oil-cooler in cylinder block
- Closed system with forced feeding
- Eco type oil filter
- Electric oil extraction pump
- Gear drive engine oil pump
- Washable auxiliary cyclone oil filter

Instrument Box Assembly

- Engine self-protection and diagnosis
- Displays CAN information
- Displays engine diagnostic error codes
- Audible alarm and control lamps
- Idle & PTO rpm adjustable switch

Exhaust System

- Coolant cooled exhaust manifold
- Cast iron exhaust pipe
- E-VGT
- (Electric Variable Geometry Turbocharger)

Emissions

- IMO Tier II
- EPA Tier III
- RCD II
- RINA
(Type Approval - Ship)

Dimensions (mm) H380

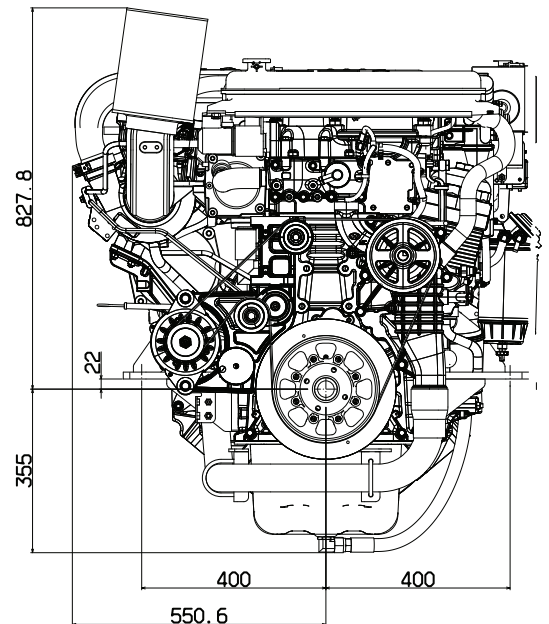
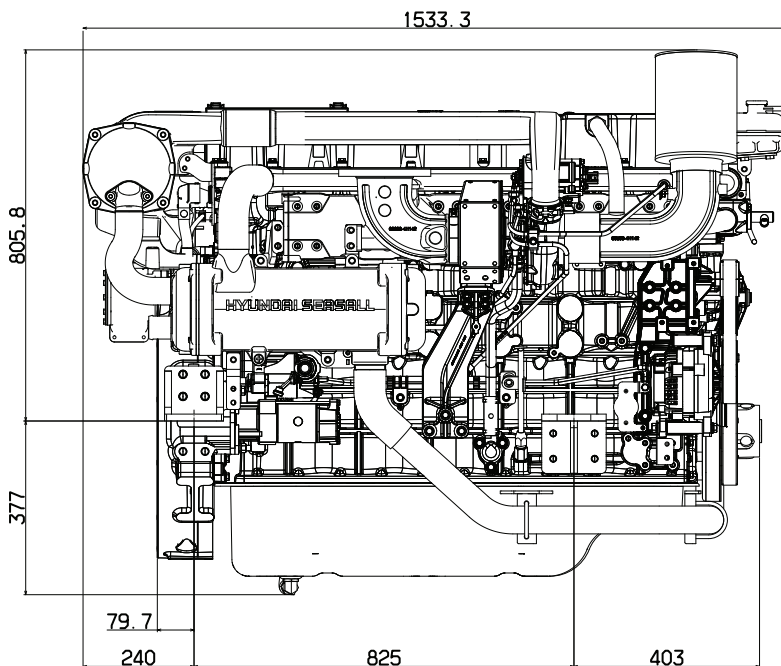

(Homepage) (e-Catalogue)



 **HYUNDAI SEASALL**

124 Jeongoksandan-ro, Seosin-myeon, Hwaseong-si, Gyeonggi-do 18554, Korea

Tel : +82-70-8620-8033 / seasall.info@hyundai-seasall.com